

Unrivalled

FlexLock

Couplings & Flange Adaptors
For Ductile Iron or Steel Pipes



PIONEERS IN PIPE SOLUTIONS

CRANE

BUILDING SERVICES & UTILITIES



Unique, Patented & Self Anchoring Joints for Ductile Iron or Steel Pipes

The FlexLock system provides a self-anchoring method of joining ductile iron or steel pipes and offers a cost effective, quick and simple alternative to traditional anchoring systems such as site welding, harnessing or thrust blocks.

Above Ground or Buried Application

FlexLock is a unique pipe jointing system that is fully end load bearing. Gaskets have embedded stainless steel teeth that grip the outer surface of the pipe, yet still allow for angular deflection of pipes in service. This prevents pipes from separating under pressure loads making FlexLock ideal for above ground and buried applications, soft ground conditions or temporary pipe work.

End Load Restraint

FlexLock works on the same compression joint principle as standard Viking Johnson products but as the compression bolts are tightened, the stainless steel teeth grip around the outside diameter of the pipe, providing a fully end load restraint joint. Internal pressure in the pipe causes the assembly to lock firmly providing a leak proof joint.

The FlexLock range consists of couplings and flange adaptors with nominal sizes from DN50 (2") up to DN300 (12") and are suitable for use on both gas and cold potable water pipelines with a maximum operating temperature of 40°C.



FlexLock Flange Adaptors

FlexLock Coupling

Pipe Materials



FlexLock Couplings & Flange Adaptors

Product Design Benefits

Suitable for Water & Gas

A FlexLock is supplied as standard with EPDM gaskets for water applications to EN 681. However it is also available with Nitrile gaskets to EN 682 suitable for natural gas, petroleum products, low aromatic fuels, sewage and drainage.

Excellent Corrosion Protection

Metal components are coated with Rilsan Nylon 11 which is WRAS approved for use with potable water. The nuts and bolts are Sheraplex coated to WIS 4-52-03, offering long term protection against corrosion, impact and abrasion to ensure continued reliable performance.

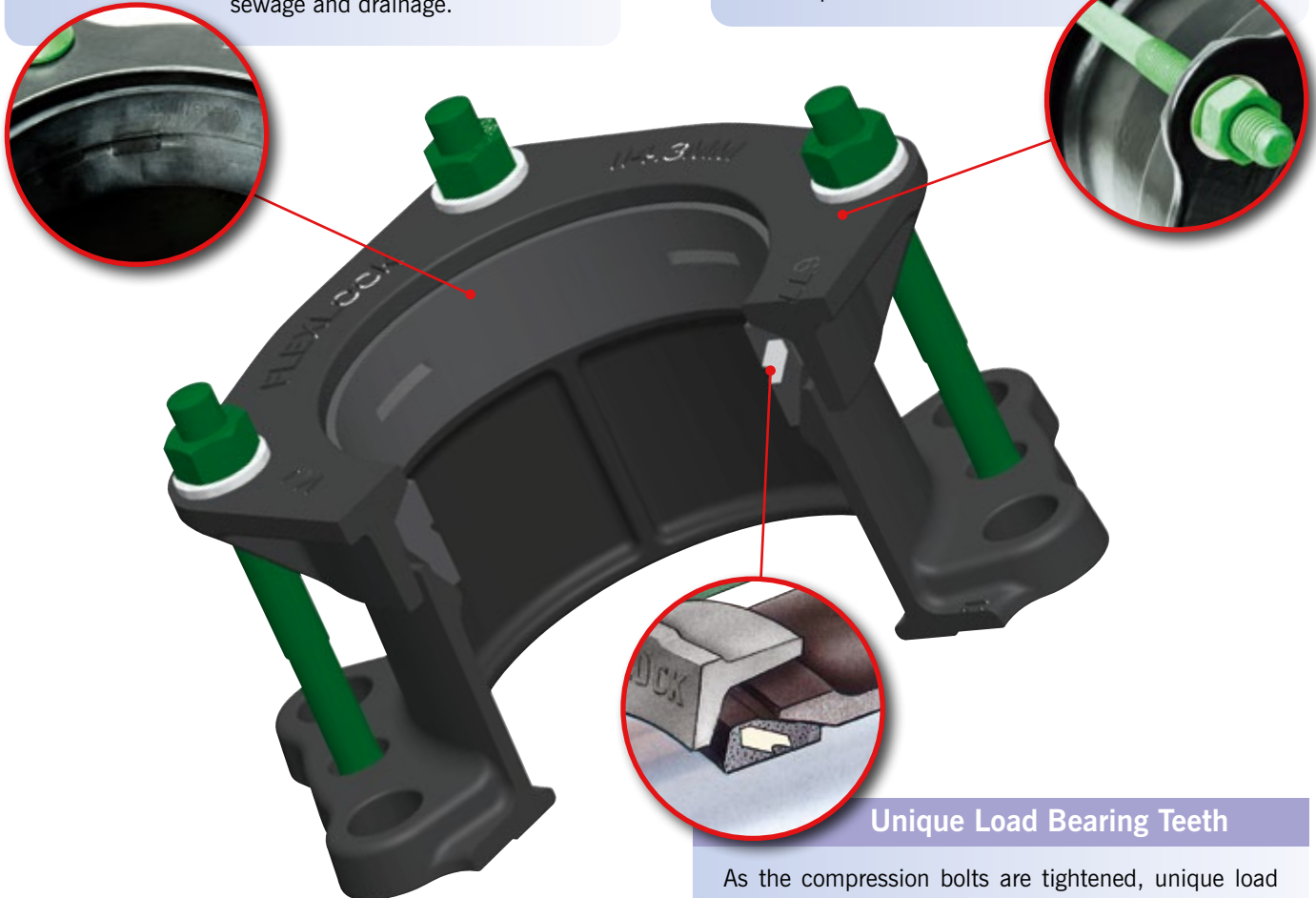

Unique Load Bearing Teeth

As the compression bolts are tightened, unique load bearing stainless steel teeth, that are moulded into the gasket grip around the outside diameter of the pipe, providing a fully end load restraint joint.

Customer Benefits

- ▶ FlexLock permits angular deflection between pipes (couplings $\pm 6^\circ$ / flange adaptors $\pm 3^\circ$), allowing for normal pipeline movement such as ground settlement. Long radius curves can also be accommodated, reducing the need for special fittings.
- ▶ Cost effective – FlexLock provides significant cost savings compared to non-locking couplings with a harnessing system.
- ▶ Restrains pressure thrusts without thrust blocks at bends.
- ▶ Convert cut lengths of pipe into flanged pipes - allows use of pipe offcuts.
- ▶ Working Pressure of 16 bar on water up to and including DN200 and 10 bar for DN250 & DN300. For gas applications a working pressure of 6 bar can be achieved.
- ▶ FlexLock provides angular deflection in ANY plane unlike a harness assembly that can only provide angular deflection in one plane.



FlexLock Unique Sealing System

How FlexLock Works

FlexLock flange adaptors and couplings work on the same compression joint principle as standard Viking Johnson products. As the compression bolts are tightened, unique load bearing stainless steel teeth (moulded into the gasket) grip around the outside diameter of the pipe, providing a fully end load resistant joint. Internal pressure in the pipe causes the assembly to lock even more firmly.

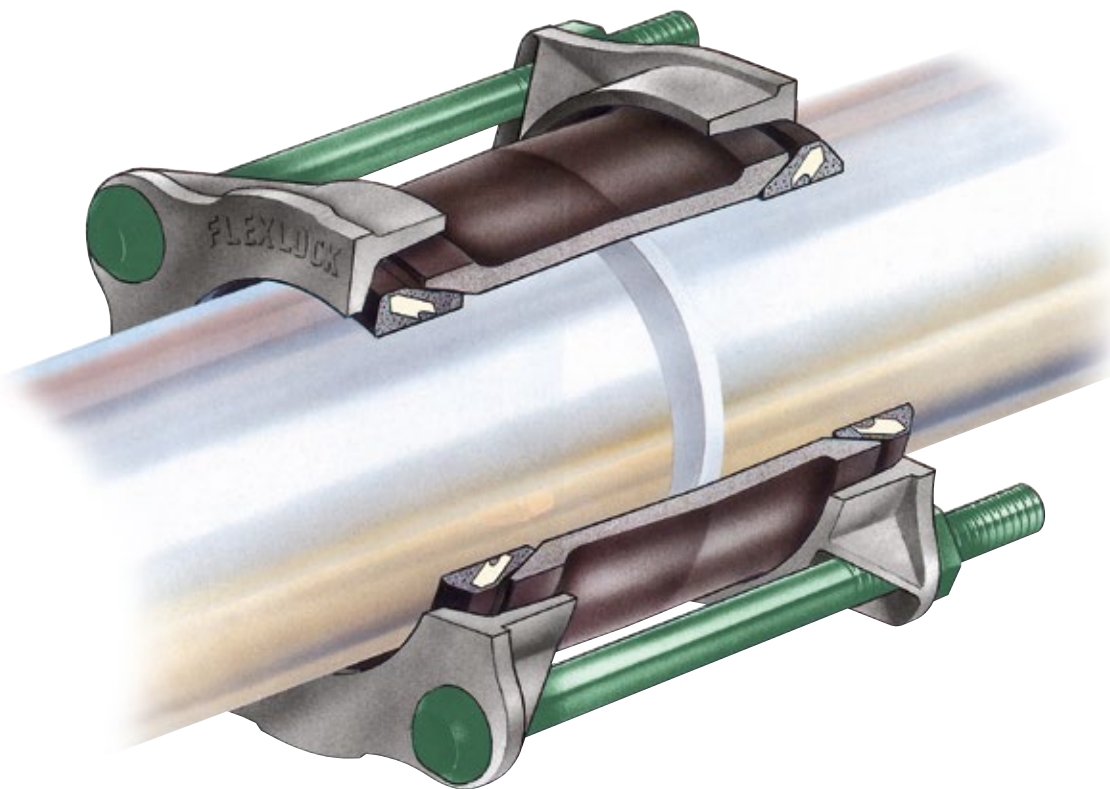

Step 1

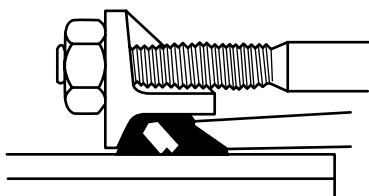

Tightening the bolts compresses the gaskets between the end rings and the centre sleeve, pressing the gasket on to the pipe and driving the edges of the steel teeth to grip on the pipe surface.

Step 2

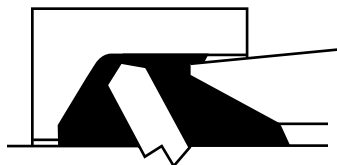

Progressive tightening of the bolts drive the teeth into their correct locked position.

Step 3

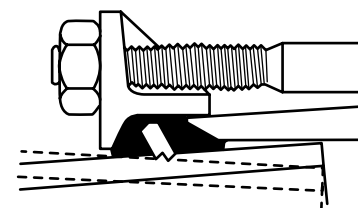

When the bolts are tightened to their correct torque, the FlexLock coupling or flange adaptor is securely locked in position providing a leak proof joint whilst at the same time allowing the joint to compensate for angular movement within the pipeline.

United Kingdom - Chesterfield

Yorkshire Water

FlexLock Flange Adaptors - DN250

Project

FlexLock installed on ductile iron pipe.

Client

Yorkshire Water

Contractor

Black & Veatch

Crane BS&U are solely the provider of products and have no direct influence on, or take any responsibility for any working practices employed or depicted in the images enclosed to install such products.

FlexLock Couplings

Datasheet

1/2

Coupling

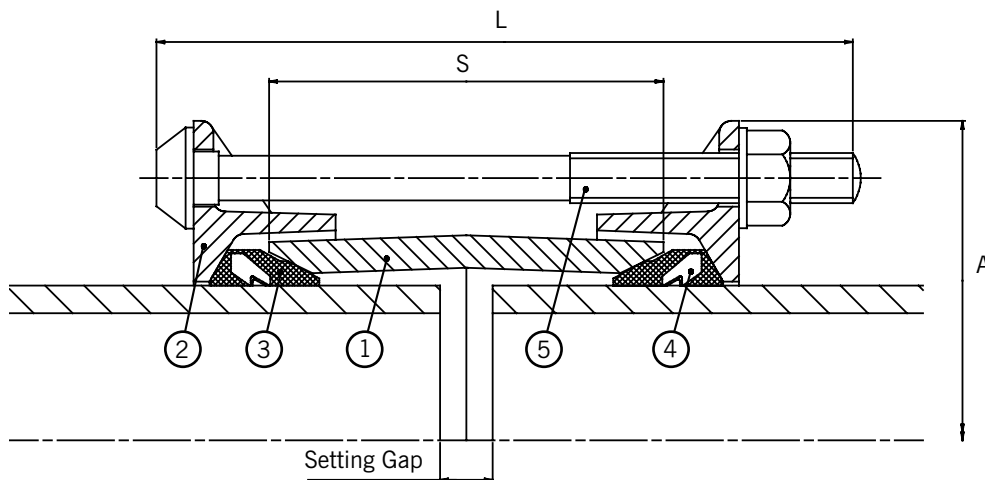

Key

- 1 = Sleeve
- 2 = End Ring
- 3 = Gasket
- 4 = Gasket Gripper Teeth
- 5 = Bolts, Nut & Washer

FlexLock Couplings

Pipe Nom	Pipe OD (mm)	Pipe Material	Bolt Size No.-Dia x Length	Overall Length (L)	End Ring OD (A)	Sleeve Length x Thickness (mm) (S)	Setting Gap		Working Pressure (bar)		Gasket Mould	Coupling Weight (kg)
							Min	Max	Water	Gas		
DN50/2"	60.3	Steel	2-M12 x 145	157	135	80 x 5.5	15	30	16	6	1375	2.7
DN65/2.5"	76.1/77	Steel	2-M12 x 160	170	152	100 x 6.0	20	40	16	6	1394	3.2
DN80/3"	88.9	Steel	4-M12 x 160	170	163	100 x 6.0	20	40	16	6	1382	4.2
DN80/3"	98.0	Ductile Iron	4-M12 x 195	203	181	115 x 6.4	20	40	16	6	1630	5.2
DN100/4"	114.3	Steel	4-M12 x 170	188	195	100 x 6.0	20	40	16	6	1367	6.1
DN100/4"	118	Ductile Iron	4-M12 x 195	203	200	115 x 6.4	20	40	16	6	1618	5.6
DN150/6"	165.1	Steel	6-M12 x 170	188	254	100 x 7.2	20	40	16	6	1369	9.2
DN150/6"	168.3	Steel	6-M12 x 170	188	256	100 x 7.2	20	40	16	6	1369	9.3
DN150/6"	170	Ductile Iron	6-M12 x 170	178	256	100 x 7.2	20	40	16	6	1369	9.2
DN200/8"	219.1	Steel	8-M12 x 170	188	310	100 x 7.2	20	40	16	6	1370	11.9
DN200/8"	222	Ductile Iron	6-M16 x 195	206	316	115 x 6.4	20	40	16	6	1631	12.0
DN250/10"	273.0	Steel	12-M16 x 275	286	376	178 x 8.5	20	40	10	6	1737	32.2
DN250/10"	274	Ductile Iron	12-M16 x 275	286	376	178 x 8.5	20	40	10	6	1737	32.2
DN300/12"	323.9	Steel	12-M16 x 275	286	436	178 x 6.0	20	40	10	6	7667/8	33.7
DN300/12"	326	Ductile Iron	12-M16 x 275	286	436	178 x 6.0	20	40	10	6	7667/8	33.7

Every effort has been made to ensure that the information contained in this publication is accurate at the time of publishing. Crane Ltd assumes no responsibility or liability for typographical errors or omissions or for any misinterpretation of the information within the publication and reserves the right to change without notice.

DR8550_03_2020_ISSUE 6

Technical Information

Working Pressure Rating

Water:

- DN50 to DN200 = 16 bar
- DN250 to DN300 = 10 bar

Gas:

- DN50 to DN300 = 6 bar

Vacuum Pressure

Capable of accommodating a vacuum pressure of -0.7 bar

Site Test Pressure

1.5 times working pressure for short duration (2 hours)

Angularity

Couplings 6°

Bolt Torque/Spanner

M12; Torque 55-65Nm on every bolt

M16; Torque 95-120Nm on every bolt

Temperature Rating of Product

EPDM -20°C to +40°C

Nitrile -20°C to +40°C

Materials & Relevant Standards

Centre Sleeve & End Ring Options:

- SG. Iron to BS 1563: Symbol EN-GJS-450-10
- Rolled Steel to: BS EN 10025: Grade S275

Coupling Body Options:

- Ductile Iron to BS EN 1563 EN-GJS-450-10
- Mild Steel to: BS EN 10025: Grade S275

Gasket

EPDM compound Grade E to BS EN 681-1

Nitrile compound Grade 'G' to BS EN 682-1

Gasket Gripper Teeth

Stainless Steel BS 3146: Part 2 Grade ANC2

General Notes

- FlexLock is only suitable for use on Ductile Iron, Steel and Coated Steel Pipe
- For coated steel pipe the maximum permitted coating thickness is 500µ DFT. This is to ensure the stainless steel teeth properly grip onto the pipe surface to mobilize the end load capability of the products.
- Due to the surface characteristics of stainless steel pipe, FlexLock grippers are unable to achieve a guaranteed grip on the pipe surface.
- If the product has to be dismantled after installation then for reassembly a new gasket must be used, as there is a risk that the stainless steel teeth may become dislodged during this operation. These are available as spares from Viking Johnson by quoting gasket mould number from the table along with gasket compound.

Approvals

The following water contact materials used in FlexLock are approved for use with potable water:-

Rilsan Nylon 11:

- WRAS, AS/NZS 4020, DVGW, W270, ACS & KIWA

EPDM Gaskets:

- WRAS, AS/NZS 4020

In addition to the above, FlexLock range as a finished product has KIWA certification verifying that the above products comply with the requirements of the Water Supply (Water Fittings) Regulations for England and Wales 1999, the Water Byelaws 2000, Scotland and the Water Regulations Northern Ireland.

Coatings

Body, Centre Sleeve, & End Rings:

- Rilsan Nylon 11 to WIS 4-52-01 Part 1

Bolts, Studs & Nuts:

- Sheraplex coated to WIS 4-52-03

Bolts

Cold Forged Steel Fasteners to: BS EN ISO898-1: Property Class 8.8

Nuts

Steel BS EN 20898-2: Property Class 8

Washers

BS 4320 Form B Stainless Steel BS 1449:PT2: Grade 304 S15

FlexLock Flange Adaptors

Datasheet

1/2

Flange Adaptor

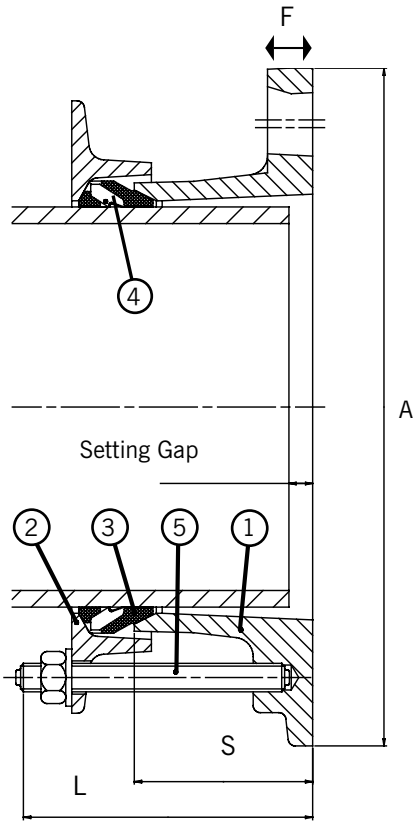

Key

- 1 = Flange Adaptor
- 2 = End Ring
- 3 = Gasket
- 4 = Gasket Gripper Teeth
- 5 = Stud

FlexLock Flange Adaptors

Pipe Nom	Pipe OD (mm)	Pipe Material	Bolt Size No.-Dia x Length	Flange OD (A)	Overall Length (L)	Flange Thickness (mm) (F)	Sleeve Length (mm) (S)	Flange Nominal Drilling BS EN 1092-1	Working Pressure (bar)		Setting Gap		Gasket Mould	FA Weight (kg)
									Water	Gas	Min	Max		
DN50/2"	60.3	Steel	2-M12 x 115	160	123	16	75	50 PN10/16	16	6	10	30	1375	2.3
DN65/2.5"	76.1	Steel	2-M12 x 115	180	123	16	75	60/65 PN10/16	16	6	10	30	1394	2.6
DN80/3"	88.9	Steel	4-M12 x 115	195	123	16	75	80 PN10/16 90 PN6	16	6	10	30	1382	3.4
DN80/3"	98	Ductile Iron	4-M12 x 115	195	123	16	75	80 PN10/16 90 PN6	16	6	10	30	1630	4.0
DN100/4"	114.3	Steel	4-M12 x 115	215	123	16	75	100 PN10/16 110 PN6	16	6	10	30	1367	4.5
DN100/4"	118	Ductile Iron	4-M12 x 115	215	123	16	75	100 PN10/16	16	6	10	30	1618	4.4
DN150/6"	165.1	Steel	8-M12 x 115	285	127	25	75	150 PN10/16 6"E 6"ANSI 150	16	6	10	30	1369	9.3
DN150/6"	168.3	Steel	8-M12 x 115	286	123	19	75	150 PN10/16	16	6	10	30	1369	8.0
DN150/6"	170	Ductile Iron	8-M12 x 115	286	123	19	75	150 PN10/16	16	6	10	30	1369	8.0
DN200/8"	219.1	Steel	8-M12 x 115	341	123	19	75	200 PN10	10	6	10	30	1370	9.7
DN200/8"	219.1	Steel	8-M12 x 115	340	127	25	73	200 PN16	16	6	10	30	1370	15.2
DN200/8"	222	Ductile Iron	6-M16 x 125	341	137	19	75	200 PN16	16	6	10	30	1631	10.6
DN200/8"	222	Ductile Iron	8-M16 x 125	340	137	25	75	200 PN10 8"E	10	6	10	30	1631	13.9
DN250/10"	273.0	Steel	12-M16 x 125	405	137	19	90	250 PN10/16*	10	6	10	30	1737	16.4
DN250/10"	274	Ductile Iron	12-M16 x 125	405	137	19	90	250 PN10/16*	10	6	10	30	1737	16.4
DN300/12"	323.9	Steel	12-M16 x 125	467	137	19	90	300 PN10/16*	10	6	10	30	7667/8	22.7
DN300/12"	326	Ductile Iron	12-M16 x 125	467	137	19	90	300 PN10/16*	10	6	10	30	7667/8	22.7

Every effort has been made to ensure that the information contained in this publication is accurate at the time of publishing. Crane Ltd assumes no responsibility or liability for typographical errors or omissions or for any misinterpretation of the information within the publication and reserves the right to change without notice.

DR8550_03_2020_ISSUE 6

Technical Information

Working Pressure Rating

Water:

- DN50 to DN200 = 16 bar
- DN250 to DN300 = 10 bar

Gas:

- DN50 to DN300 = 6 bar

Vacuum Pressure

Capable of accommodating a vacuum pressure of -0.7 bar

Site Test Pressure

1.5 times working pressure for short duration (2 hours)

Flange Drilling

While DN250 to DN300 are supplied with PN1616 drilling the rated working pressure (water) is only 10 bar as stated in the table.

Angularity

Flange Adaptors 3°

Bolt Torque/Spanner

M12; Torque 55-65Nm on every bolt

M16; Torque 95-120Nm on every bolt

Temperature Rating of Product

EPDM -20°C to +40°C

Nitrile -20°C to +40°C

Materials & Relevant Standards

End Rings Options:

- SG. Iron to BS 1563: Symbol EN-GJS-450-10
- Rolled Steel to: BS EN 10025: Grade S275

Flange Adaptor Body Options:

- Ductile Iron to BS EN 1563 EN-GJS-450-10
- Mild Steel to: BS EN 10025: Grade S275

Gasket

EPDM compound Grade E to BS EN 681-1

Nitrile compound Grade 'G' to BS EN 682-1

Gasket Gripper Teeth

Stainless Steel BS 3146: Part 2 Grade ANC2

General Notes

- FlexLock is only suitable for use on Ductile Iron, Steel and Coated Steel Pipe
- For coated steel pipe the maximum permitted coating thickness is 500µ DFT. This is to ensure the stainless steel teeth properly grip onto the pipe surface to mobilize the end load capability of the products.
- Due to the surface characteristics of stainless steel pipe, FlexLock grippers are unable to achieve a guaranteed grip on the pipe surface.
- If the product has to be dismantled after installation then for reassembly a new gasket must be used, as there is a risk that the stainless steel teeth may become dislodged during this operation. These are available as spares from Viking Johnson by quoting gasket mould number from the table along with gasket compound.

Approvals

The following water contact materials used in FlexLock are approved for use with potable water:-

Rilsan Nylon 11:

- WRAS, AS/NZS 4020, DVGW, W270, ACS & KIWA

EPDM Gaskets:

- WRAS, AS/NZS 4020

In addition to the above, FlexLock range as a finished product has KIWA certification verifying that the above products comply with the requirements of the Water Supply (Water Fittings) Regulations for England and Wales 1999, the Water Byelaws 2000, Scotland and the Water Regulations Northern Ireland.

Coatings

Body, Centre Sleeve, & End Rings:

- Rilsan Nylon 11 to WIS 4-52-01 Part 1

Studs & Nuts:

- Sheraplex coated to WIS 4-52-03

Studs

Cold Forged Steel Fasteners to: BS EN ISO898-1: Property Class 8.8

Nuts

Steel BS EN 20898-2: Property Class 8

Washers

BS 4320 Form B Stainless Steel BS 1449:PT2: Grade 304 S15

United Kingdom - Liverpool

West East Link Main

FlexLock - DN150

Large Diameter - DN800



Project

West East link transmission main.
The 53km pipeline runs from Prescot near Liverpool to Bury, near Manchester.

Client

United Utilities

Contractor

Murphys

Crane BS&U are solely the provider of products and have no direct influence on, or take any responsibility for any working practices employed or depicted in the images enclosed to install such products.



46-48 WILBURY WAY
HITCHIN, HERTFORDSHIRE
SG4 0UD. UNITED KINGDOM
TELEPHONE: +44 (0)1462 443322
FAX: +44 (0)1462 443311
EMAIL: info@vikingjohnson.com

www.vikingjohnson.com

DUBAI SALES OFFICE
CRANE BS&U
BUILDING 4, OFFICE 901
THE GALLERIES
PO BOX 17415
DOWNTOWN JEBEL ALI
DUBAI. UAE
TELEPHONE: +971 4816 5800



FM 00311

EMS 553775



To visit our Video Library go to:
www.youtube.com/user/CraneBSU

- Designed and manufactured under quality management systems in accordance with BS EN ISO 9001.
- Environmental Management System accredited to ISO 14001.
- For full terms and conditions, please visit our website.

Every effort has been made to ensure that the information contained in this publication is accurate at the time of publishing. Crane Ltd assumes no responsibility or liability for typographical errors or omissions or for any misinterpretation of the information within the publication and reserves the right to change without notice.

DR9560_03_2020_ISSUE 6

PIONEERS IN PIPE SOLUTIONS



www.cranesbu.com

