

Couplings

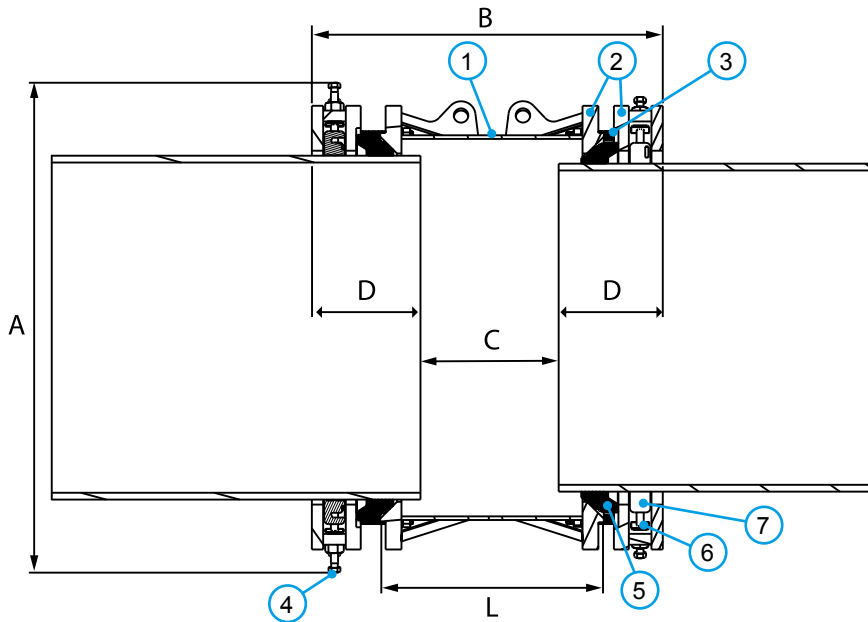

Key

- 1 = Centre Sleeve
- 2 = End Ring
- 3 = Studs
- 4 = Bolt, Nut & Washer
- 5 = Gasket
- 6 = Square Bush Nut
- 7 = Gripper



HAZARD WARNING: Lifting lugs, where provided, are designed/tested for lifting only the components to which they are attached. Failure to follow these instructions could result in property damage, serious personal injury or death. The maximum safe working load of the lifting eye is equal to the product weight.

Couplings

Nom Size	Size Range (mm)		Insertion Depth (D) (mm)		Setting Gap (C) (mm)		Dimensions (mm)			Fasteners		Weight (kg)
	Min	Max	Min	Max	Min	Max	Overall		Sleeve	Axial Stud No-size	Radial Bolt No-size	
							A	B				
700	700	735	220	325	165	375	1085	815	495	32 x M20	48 x M16	559
700	727	762	220	325	165	375	1115	815	495	32 x M20	64 x M16	591
700	750	785	220	325	165	375	1135	815	495	32 x M20	48 x M16	592
800	789	824	220	325	170	380	1175	820	500	36 x M20	60 x M16	638
800	825	860	220	325	170	380	1210	820	500	36 x M20	80 x M16	684
800	853	888	220	325	170	380	1240	820	500	36 x M20	60 x M16	680

Connections based on standard pipe OD's*

Nom Size	Range		Ductile Iron	PE / MOPVC	Steel / FBE Coated Steel	Cast Iron	Asbestos Cement
	Min	Max					
DN700	700	735		710mm	DN700	26" (AB & CD)	26" (AB & CD)
DN700	727	762	DN700			27" (AB & CD)	27" (AB & CD)
DN700	750	785			DN750	28" (AB & CD)	28" (AB & CD)
DN800	789	824		800mm	DN800	30" (AB)	30" (AB)
DN800	825	860	DN800				
DN800	853	888				32" (AB & CD)	32" (AB & CD)

*The above table is for guidance only, please ensure the OD and material of the pipe is compatible before installation

Working Pressure & Temperature Ratings

Nominal Size	Gripping Product		Flex Product		Operating Temperature
	Gas	Water	Gas	Water	
DN700	N/A	16 bar	N/A	16 bar	-20 to +60
DN800	N/A	16 bar	N/A	16 bar	

Pipe Materials



Every effort has been made to ensure that the information contained in this publication is accurate at the time of publishing. Crane Ltd assumes no responsibility or liability for typographical errors or omissions or for any misinterpretation of the information within the publication and reserves the right to change without notice.

Couplings

Technical Information

Working pressure rating:

Water:
DN700 to DN800 = 16 bar
Gas:
Not approved

Site test pressure:

1.5 times working pressure

Angularity

Couplings 8°, +/- 4° angularity on each side

Gripping product suitable for

Ductile iron / PE (PE100, SDR 11, 17, 21, 26)
Steel / Cast iron / MOPVC (SDR 33)

Flex product suitable for

Ductile Iron / PE (PE100, SDR 11, 17, 21, 26)
Steel / Cast Iron / MOPVC / Asbestos Cement

Bolt Torque	Recommended Bolt Torque (Nm) on every bolt				
	Bolt Size	Ductile Iron	PE-100	Steel & Cast Iron	MOPVC
Axial Fastener (For Gasket Engagement)	M20	190-210	190-210	190-210	190-210
Radial Fastener (For Grippers)	M16	175-185	140-150	110-120	95-105

For the full installation details and to ensure correct fitting, please refer to the Ultragrip DN700 DN800 installation instructions.

Temperature rating of product

Operating temperature -20°C to +60°C

Support liners – PE and MOPVC pipes

A close fit Viking Johnson support liner is required when used on:

- > All PE pipes
- > MOPVC pipes

Use of restrained couplings on exposed pipework

Above ground exposed pipework is subject to both loads from the internal pressure and those from temperature changes / thermal expansion, which can be substantially higher than those from internal pressure and cannot always be safely determined. UltraGrip can be used in above ground applications, where it is not exposed to direct sunlight, and falls within the 40°C operating temperature range (between -20°C and +60°C).

Approvals

The following water contact materials used in UltraGrip are approved for use with potable water:-

Rilsan Nylon 11:

- > WRAS, AS/NZS 4020, DVGW, W270, ACS & KIWA

Gasket (EPDM):

- > WRAS, W270

Finished Product:

BS8561; WRc certification verifying that the product complies with BS8561 (Specification for mechanical fittings for use in the repair, connection and renovation of pressurized water supply pipelines — Requirements and test methods).

Polyethylene Pipe Pull Out Performance; WRc certification confirming on PE a Type 2 end load performance (defined in IGN 4-01-02:2017 [N3]) when tested in accordance with the method given in BS EN ISO 3501.

Materials & Relevant Standards

1) End Rings 2) Centre Sleeve

Mild steel to BS EN10025 Grade S355

3) Studs

Stainless steel – BS EN ISO 3506-1
Grade A4-80

4) Bolts

Stainless steel to BS EN ISO 3506-1
Grade A4-80

4) Nuts

Stainless steel – BS1449:PT2 ISO 3506-1
Grade A4-80

4) Washers

Stainless steel – BS1449:PT2 ISO 3506-1
Grade A4-50

5) Gasket

EPDM to BS EN 681-1

6) Square Bush Nut

Cast stainless steel to ASTM
A487/A487M-21, Grade CA6NM Class A

7) Gripper

Stainless steel (Cast) PH 17-4 H925
to BS EN 10088-1

Retention Insert

Nylon 6

Coatings

End Rings / Centre Sleeve / Flange:

- > Rilsan Nylon 11 (Black)

Bolts:

- > Dry Film Lubricant GZ – Silver

Nuts:

- > Dry Film Lubricant GZ – Silver

Gripper - None